



Lampade LED resistenti all'acqua, agli olii e alle vibrazioni, adatte per applicazioni su macchine utensili e ambienti con liquidi ad alta temperatura.

Illuminazione ad alta intensità e più focalizzata grazie all'ottica. Per ambienti dove è richiesta un'illuminazione, a lunga distanza, intensa e lineare.

Ottima resistenza agli olii grazie ad una speciale struttura di tenuta con grado di protezione IP67, adatto per applicazioni su macchine utensili con fluidi da taglio. Adatto per ambienti con liquidi ad alta pressione e alta temperatura (IP69K). Vetro temprato previene i danni da trucioli di macchine utensili.

Le sostanze estranee non si accumulano sulla superficie del vetro di schermatura grazie alla sua struttura a filo della cornice. Ingresso cavi standard incluso.

Water, vibration and oil resistant LED work light, suitable for machine tools applications and high temperature water cleaning environments.

High intensity illumination and condensor lens combination.

High intensity illumination allows for the environment both long distance and straightness are required.

Excellent oil resistance with a special sealing structure with IP67 protection rating, suitable for machine tool applications with cutting fluids.

Suitable for high pressure and high temperature water cleaning environments (IP69K).

Tempered glass prevents damage from machine tool chips.

Foreign substances do not accumulate on the shielding glass surface of the working light due to its flush structure to the housing structure of the product. Standard entry cable included.

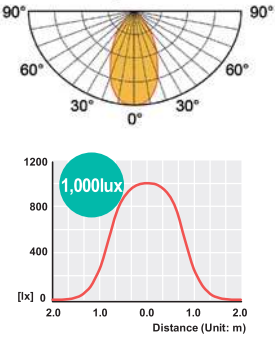

Caratteristiche - Features	DTS-LED QMHL-150
Distribuzione della intensità luminosa <i>Luminous intensity distribution</i>	
Illuminamento <i>Illumination</i>	
Ottica / Lens color	Trasparente - Transparent
Temperatura colore <i>Color temperature</i>	6000-7000 K
Flusso luminoso <i>Luminous flux</i>	884 lm
Illuminamento <i>Illumination (at 1m)</i>	1000 lux
Intervallo di tensione <i>Voltage range</i>	21.5-26.5 VDC
Corrente / Current	0.510 A
Resistenza di isolamento <i>Insulation resistance</i>	Min. 100 MΩ (500 VDC mega ohm meter)
Tensione di tenuta <i>Withstanding voltage</i>	500 VAC, 60 Hz, 1 min.
Temperatura operativa <i>Operating temperature</i>	-30°C ... +60°C
Grado di isolamento <i>Waterproof</i>	IP67 / IP69K
Materiale / Materials	Ottica: vetro temprato - Corpo e staffa: alluminio / Lens: tempered glass - Housing and bracket: aluminum

Staffa MF - MF bracket



Le staffe MF proteggono i cavi di uscita dall'acqua e dagli agenti aggressivi.
Water and oil resistant MF type brackets protect output cable from cutting fluid and chips.

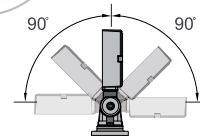

Rotazione - Vista di lato
Tilt adjustment - Side view

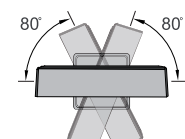

Rotazione - Vista dall'alto
Pan adjustment - Top view

Dimensioni / Dimensions

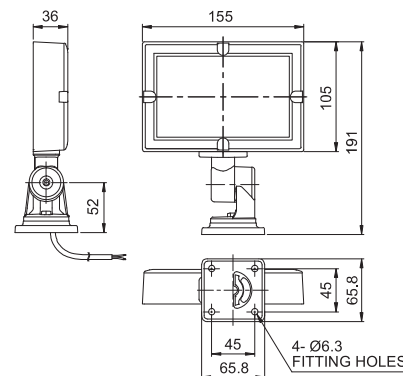

Cavo in dotazione / Power line standard:
Dura&Flex - F VU(0.5sqx2C) 450 mm
Lunghezza cavo / Cable length: 3 m

MODELLI <i>Model List</i>	Codice <i>Code</i>	Assorbimento <i>Power cons.</i>	Tensione d'ingresso <i>Input voltage</i>	Fascio luminoso <i>Beam</i>	Dimensioni <i>Dimensions</i>	Peso <i>Weight</i>
DTS-LED QMHL-150-MF	34791HF150	12 W	24 VDC	60°	155 x 105 x 36 mm	1.45 kg