



EMC bracket with strain relief for OSF family

NEW

- ▶ Suitable for a cable ranges from 1,5 to 9 mm
- ▶ Direct mounting on PCB
- ▶ **Increased wings length for easier cable insertion**
- ▶ Constant pressure of the spring on the cable sheath without having to run tests and checks



Model	Code	Clamp dimensions H [mm]	Pcs /pack
BROSF-16-1,5-3	1734052316	16,5	10
BROSF-16-3-6	1734052317	16,5	
BROSF-20-1,5-3	1734052320	20,5	10
BROSF-20-3-6	1734052321	20,5	
BROSF-25-1,5-3	1734052325	25,5	10
BROSF-25-3-6	1734052326	25,5	
BROSF-32 -1,5-3	1734052332	32,5	10
BROSF-32 -3-6	1734052333	32,5	

The OSF EMC brackets allow grounding and strain relief of the shielded cables when installed in the OSF splittable cable glands family.

There are 4 models for the relevant metric openings M16, M20, M25 and M32 with two models of shield clips from 1.5 to 6mm. Other diameters can be supplied upon request.

Technical data

Material: Stainless steel SS304

Altri modelli su richiesta

Dimensions [mm]

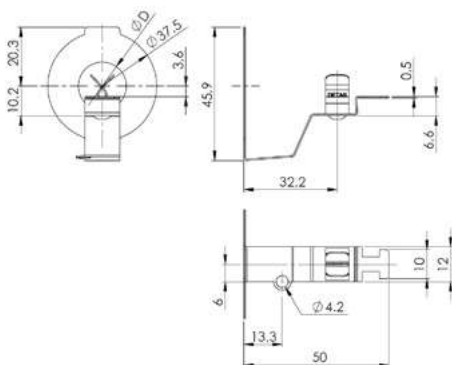

4